

"PIECE GOODS" DISPLAY with sample presentation system

Window DECORATIONS – the latest

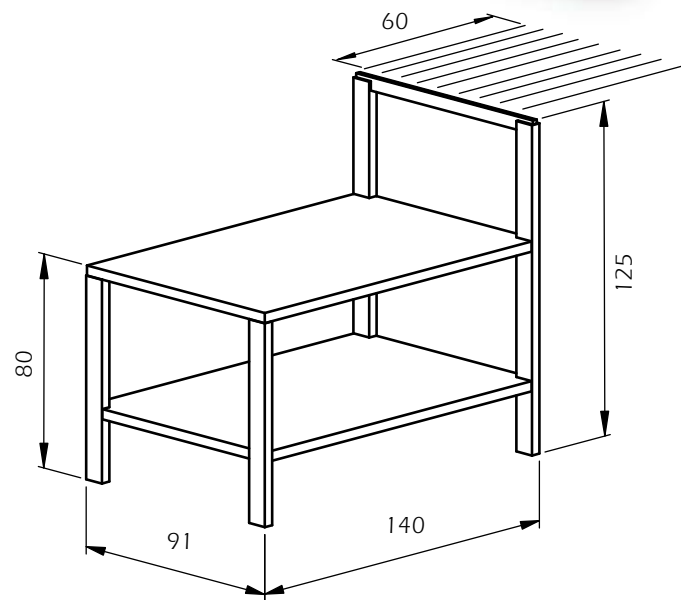

Demonstration samples: up to 40
Stand capacity: up to 18 semi-finished products
Dimensions: see drawing
Version: solid wood, painted black

The presentation tables should be positioned next to one another or back to back. You can also order the stands with or without the demonstration part.



horn textiles

PRESENTATION SYSTEMS for optimum sales

CURTAIN PANEL DISPLAY

with sample presentation system

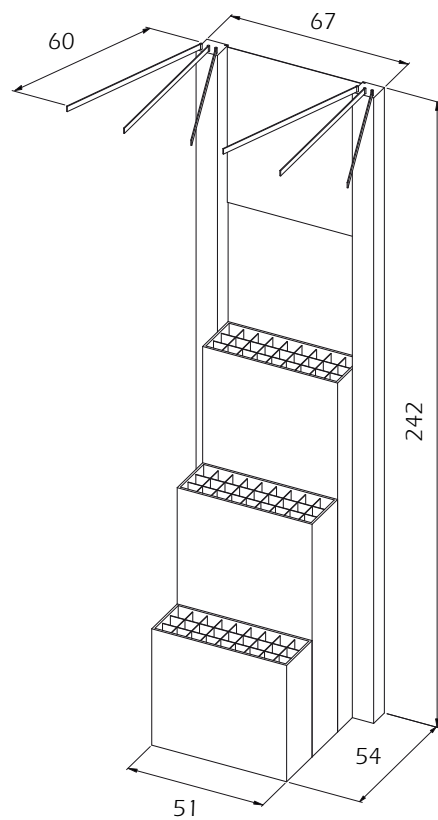

Demonstration samples: up to 22
Stand capacity: 27 different designs, 81 items in total
Dimensions: see drawing
Version: solid wood, painted black

All presentation stands should be positioned next to one another or back to back. You can also order the stands with or without the demonstration part. The photos shown on the presentation system can be swapped as you require.

BOX-TYPE CURTAIN PANEL DISPLAY

Stand capacity: 27 different designs
Dimensions (W x H x D): 49.3 x 156 x 30 cm
Version: printed cardboard, base colour black or white



READY-MADE CURTAINS DISPLAY

with sample presentation system

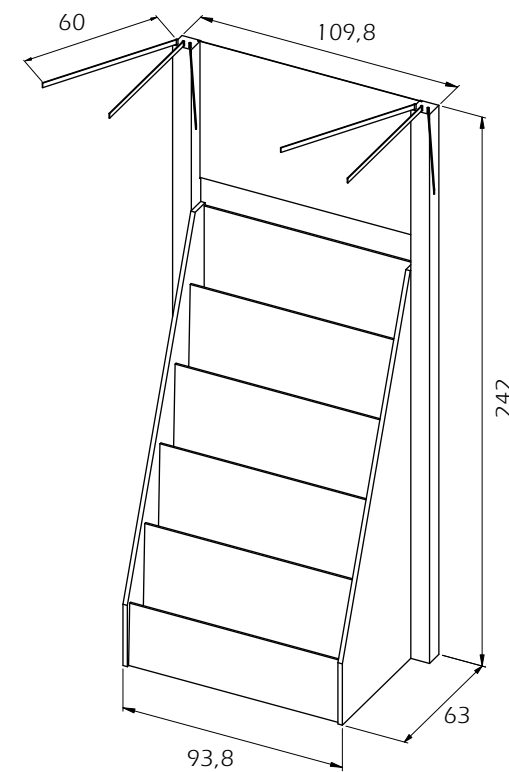

Demonstration samples: up to 22
Stand capacity: 15 different designs, 60 items in total
Dimensions: see drawing
Version: solid wood, painted black

